

CAD FILE:

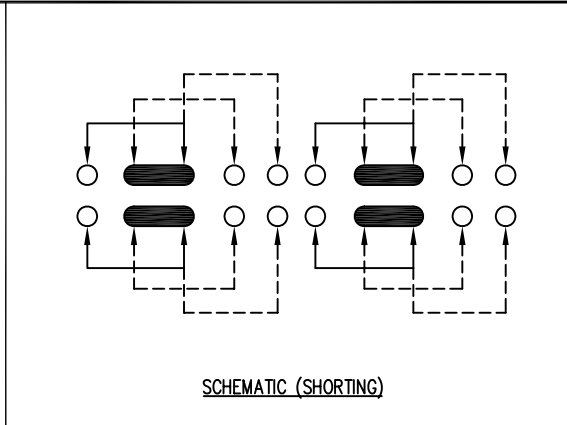
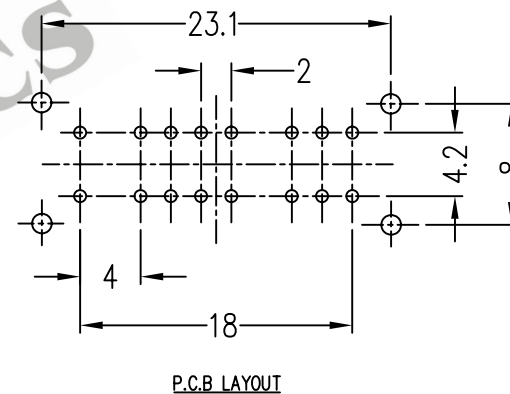
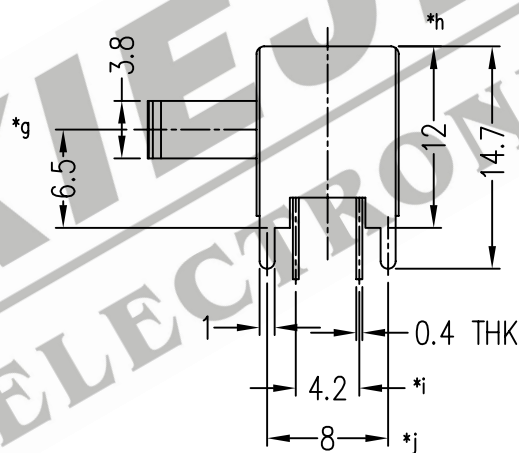
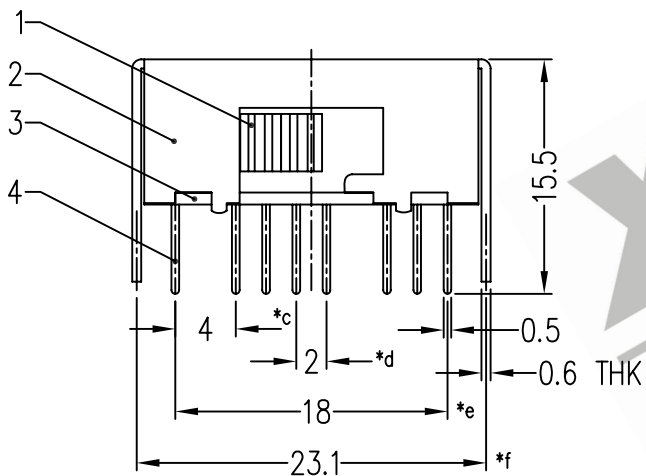
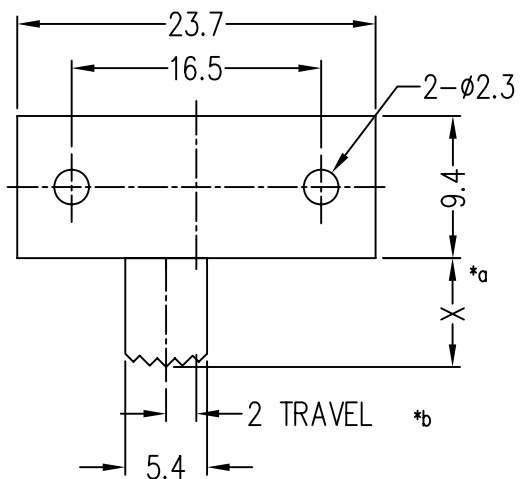

注：“*”表示关键尺寸（10个）

8					TOLERANCE UNLESS SPECIFIED	SHENZHEN XIEJIA ELECTRONICS CO.,LTD.				
7	STEEL BALL	STEEL	1	NATURAL	WITHIN: 1.5 ±0.1mm	ISSUE	DATE	DESCRIPTIONS OF REVISION		APPD.
6	SPRING	STEEL WIRE	1	TEMPER	OVER: 1.5 ±0.2mm					
5	CONTACT CLIP	PBS STRIP	4	Ag PLATED	TITLE : HORIZONTAL SLIDE SWITCH	UNIT : mm	DRWG NO.: XJ-DR-SK43D11-00			
4	TERMINAL	BRASS STRIP	16	Ag PLATED OVER Ni PLATED	MODEL: SK-43D11	SCALE: 2:1	DWN.	ZHOUYU	2001-12-26	
3	BASE	PHENOLIC RESIN	1	NATURAL	ALL MATERIALS MUST BE COMPLIANT TO ROHS		CHK'D	FANGYING	2001-12-26	
2	FRAME	STEEL STRIP	1	Ni PLATED			APPD.	KANGXINAN	2001-12-26	
1	KNOB	POM	1	BLACK						
NO.	PARTS	MATERIALS	Q'TY	FINISH						